

No damper regulator better meets the widely varied engineering demands of efficient, no-leak duct systems.

Call for Cain quality and economy.

- Air leak-minimizing design for noiseless performance in high velocity air distribution systems.
- Heavy duty cast alloy construction.
- Mounting holes for fast, easy installation using rivets, bolts, or screws.
- Convenient self-locking design.
- Competitively priced and available through wholesalers nationwide.

Cain offers you a complete line of quality engineered damper regular components for all classifications of ductwork. Our wide selection allows you to meet the toughest engineering and quality standards in the business. And Cain prices are hard to beat.

For efficient air leak-minimizing systems that are a credit to **your** name, call for Cain. Quality engineered regulators and a complete line of HVAC parts and accessories.



Never say can't say Cain!



Cain

MANUFACTURING COMPANY, INC.

QUALITY HVAC PRODUCTS SINCE 1935

2956 Highway 11 South • PO BOX 1000 • Pelham, Alabama 35124

Phone: 205-663-2200 • Fax: 205-663-2298

Web: www.cainmfg.com • E-mail: sales@cainmfg.com

Tekline Regulators, Hardware, and Accessories

ALL DIMENSIONS ARE ± .005" UNLESS NOTED

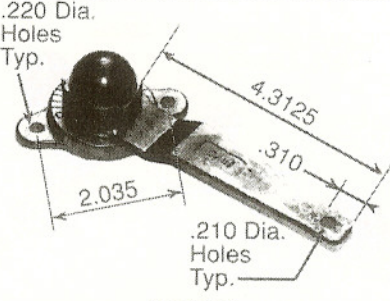
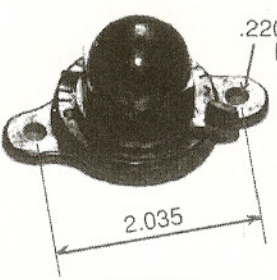
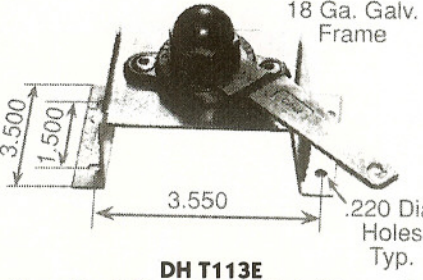
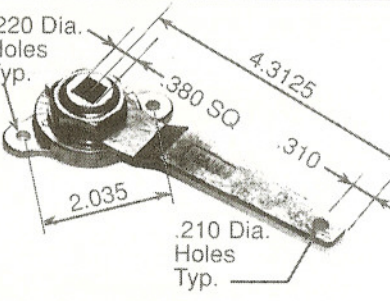
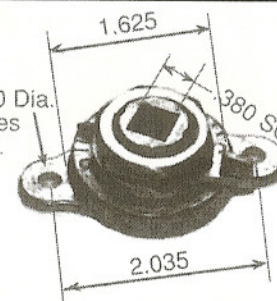
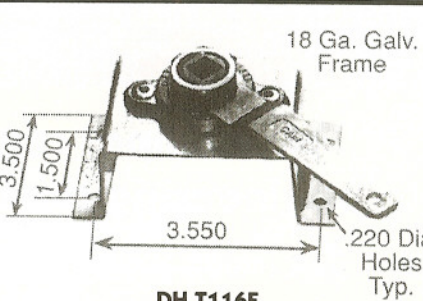
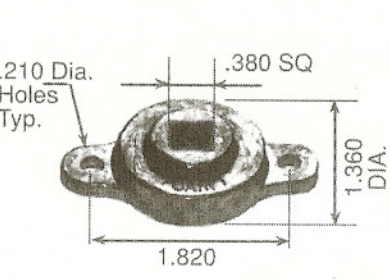
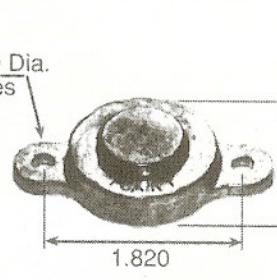
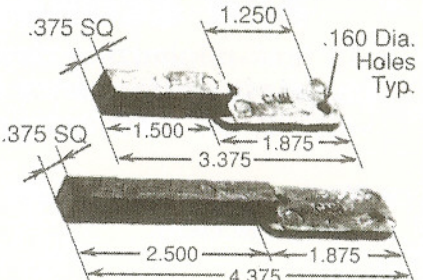
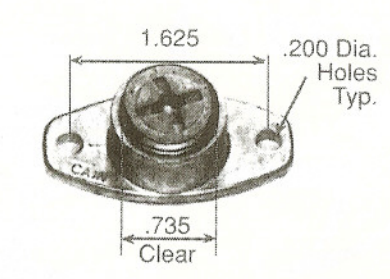
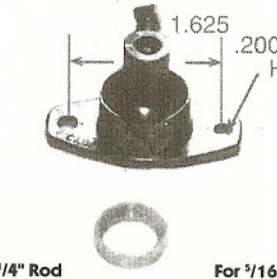
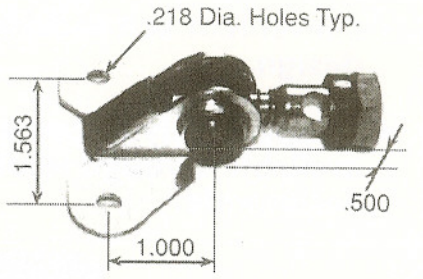
 <p>.220 Dia. Holes Typ. 4.3125 2.035 .310 .210 Dia. Holes Typ.</p> <p>DH T113 Handle Regulator Set (Acorn)</p>	 <p>.220 Dia. Holes Typ. 2.035</p> <p>DH T107 Indicator Regulator Set (Acorn)</p>	 <p>18 Ga. Galv. Frame 3.500 1.500 3.550 .220 Dia. Holes Typ.</p> <p>DH T113E Elevated Regulator Set (Acorn) Available in 1" or 1/2" Elevation</p>
 <p>.220 Dia. Holes Typ. 4.3125 3.80 SQ 2.035 .310 .210 Dia. Holes Typ.</p> <p>DH T116 Handle Regulator Set (Hex)</p>	 <p>1.625 .220 Dia. Holes Typ. 3.80 SQ 2.035</p> <p>DH T110 Indicator Regulator Set (Hex)</p>	 <p>18 Ga. Galv. Frame 3.500 1.500 3.550 .220 Dia. Holes Typ.</p> <p>DH T116E Elevated Regulator Set (Hex) Available in 1" or 1/2" Elevation</p>
 <p>.210 Dia. Holes Typ. 3.80 SQ 1.360 DIA. 1.820</p> <p>DH T101 Open End Bearing</p>	 <p>.210 Dia. Holes Typ. 1.360 DIA. 1.820</p> <p>DH T104 Closed End Bearing</p>	 <p>.375 SQ 1.250 .160 Dia. Holes Typ. 3.75 SQ 1.500 1.875 3.375 2.500 1.875 4.375</p> <p>Zinc Cast Alloy Square End Bearings DH B38 DH B38L (Long)</p>
 <p>1.625 .200 Dia. Holes Typ. .735 Clear</p> <p>DH ITP-1 Instrument Test Port With Gasket</p>	 <p>1.625 .200 Dia. Holes Typ.</p> <p>For 1/4" Rod DH SDC14 For 5/16" Rod DH SDC516 Ball Joint with nylon washer and gasket</p>	 <p>.218 Dia. Holes Typ. 1.563 1.000 .500</p> <p>For 1/4" Rod DH SDB40 For 5/16" Rod DH SDB50 Splitter Damper Bracket</p>

Cain

MANUFACTURING COMPANY, INC.

QUALITY HVAC PRODUCTS SINCE 1935

2956 Highway 11 South • PO BOX 1000 • Pelham, Alabama 35124

Phone: 205-663-2200 • Fax: 205-663-2298

Web: www.cainmfg.com • E-mail: sales@cainmfg.com

See **CAIN**
Product Catalog for
complete details.

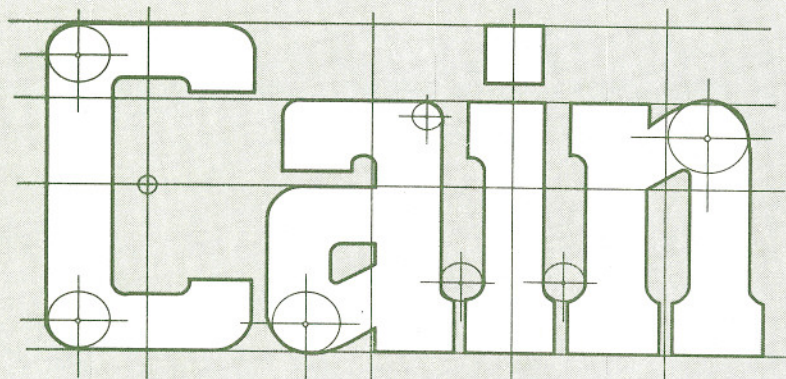

**1/4" DIAL REGULATOR
BRACKET**

**ELEVATED
1", 1 1/2" & 2"**

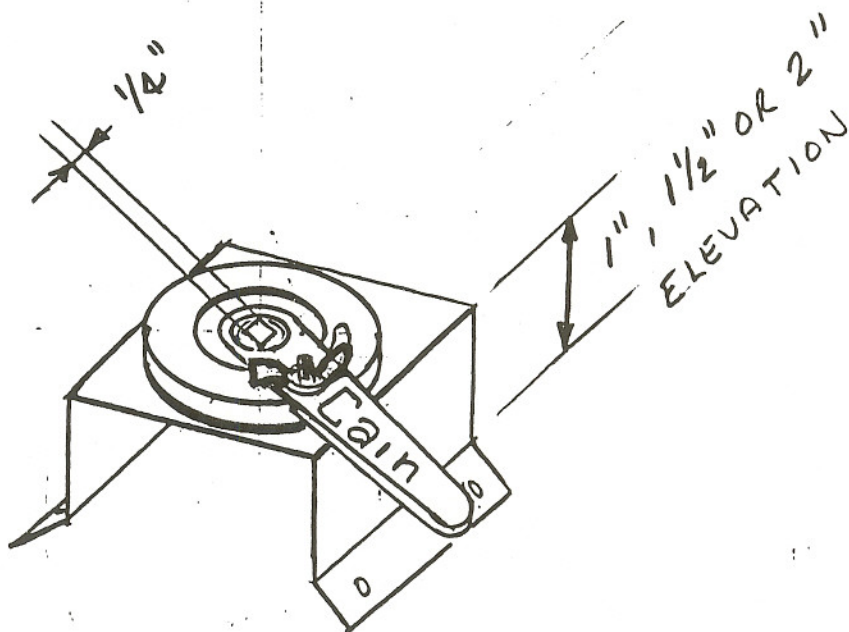

MODELS

- DH DRE 1410 1/4" DIAL REGULATOR ELEVATED 1"**
DH DRE 1415 1/4" DIAL REGULATOR ELEVATED 1 1/2"
DH DRE 1420 1/4" DIAL REGULATOR ELEVATED 2"

Cain
MANUFACTURING COMPANY, INC.
QUALITY HVAC PRODUCTS SINCE 1935

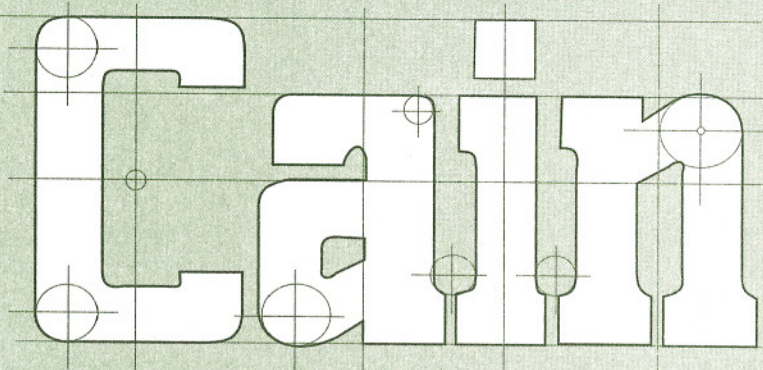

**1/4" OR 3/8"
ELEVATED DAMPER
HARDWARE**

**ELEVATED
1", 1 1/2" & 2"**

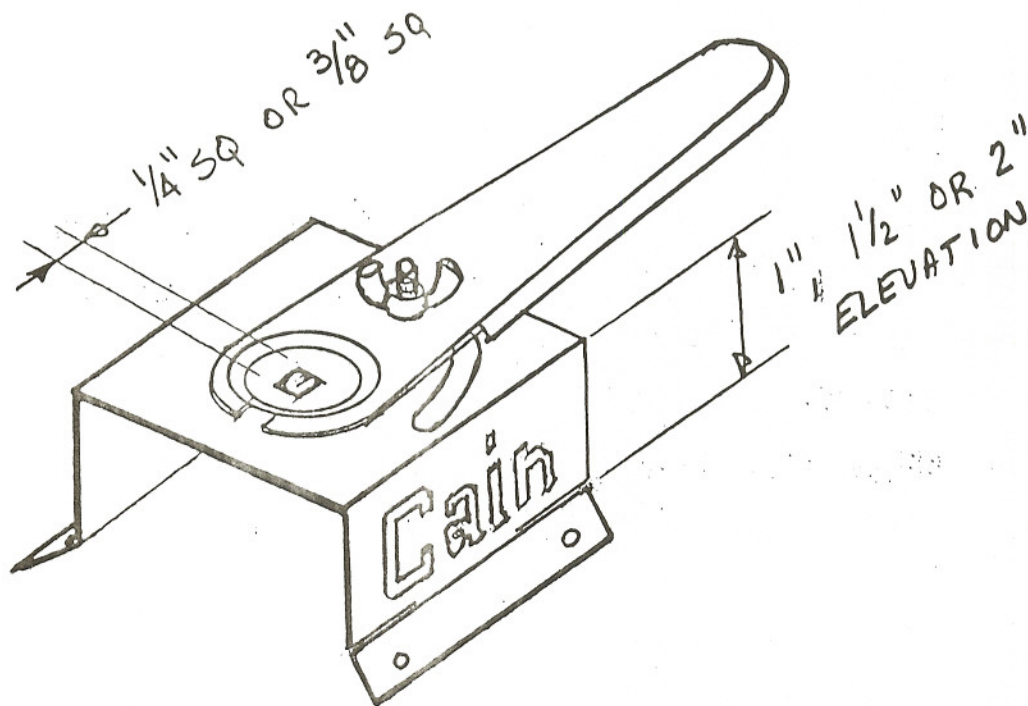

MODELS

- DH ER 1410 1/4" REGULATOR ELEVATED 1"
- DH ER 1415 1/4" REGULATOR ELEVATED 1 1/2"
- DH ER 1420 1/4" REGULATOR ELEVATED 2"
- DH ER 3810 3/8" REGULATOR ELEVATED 1"
- DH ER 3815 3/8" REGULATOR ELEVATED 1 1/2"
- DH ER 3820 3/8" REGULATOR ELEVATED 2"

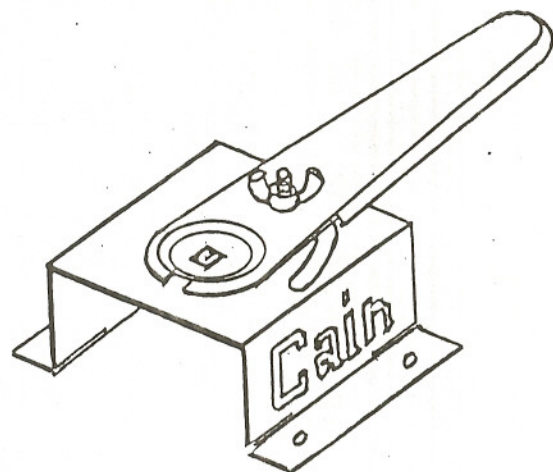

Cain
MANUFACTURING COMPANY, INC.
QUALITY HVAC PRODUCTS SINCE 1935

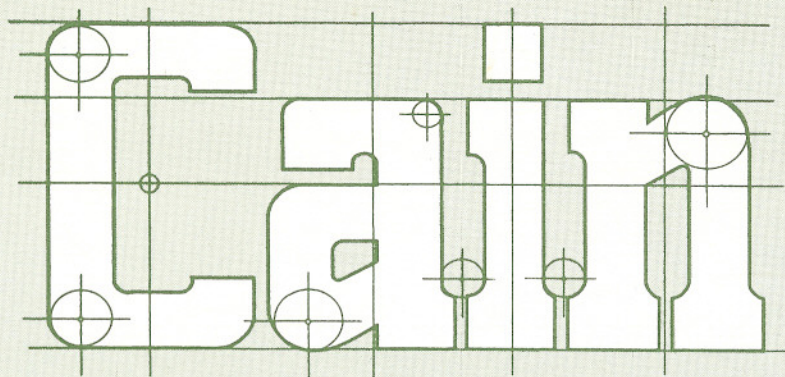

**EXTENSIONS SETS
HAMMERS-ON
HARDWARE**

**ELEVATED
1 1/2"**

EXTENSIONS FOR HAMMER ON HARDWARE

SHAFT EXTENSION
W/ LOCKING SCREW



STAND OFF

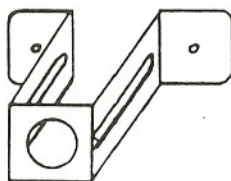

WASHER HANDLE WING NUT



MODELS

DH K 708 ES
DH K 708 ESB

EXTENSION SETS 100/CTN
EXTENSION SETS 1000/BULK

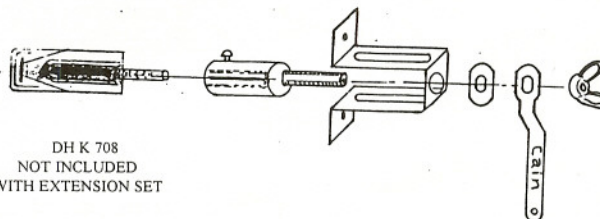

DH K 708
NOT INCLUDED
WITH EXTENSION SET

Cain
MANUFACTURING COMPANY, INC.
QUALITY HVAC PRODUCTS SINCE 1935

P.O. Box 1000 • Pelham, AL 35124 • 205-663-2200 • 1-800-554-0342 • FAX 205-663-2298

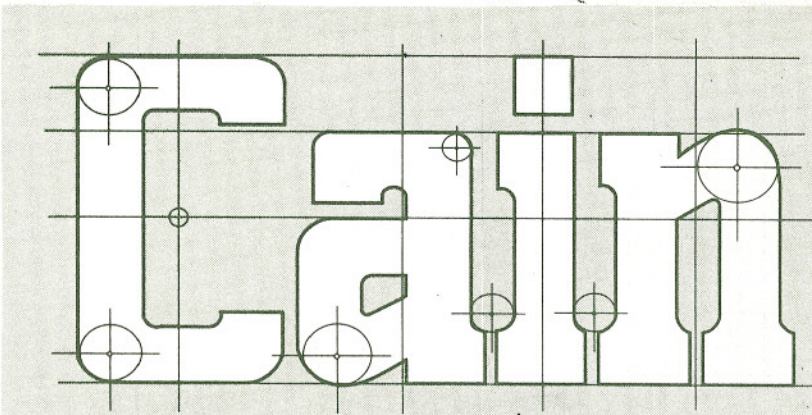

**ELEVATED
SPADE ASSEMBLY**

DH ESA 10	1"
DH ESA 15	1 1/2"
DH ESA 20	2"

TAKE OFF

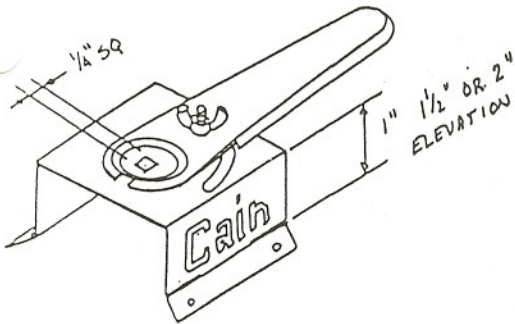
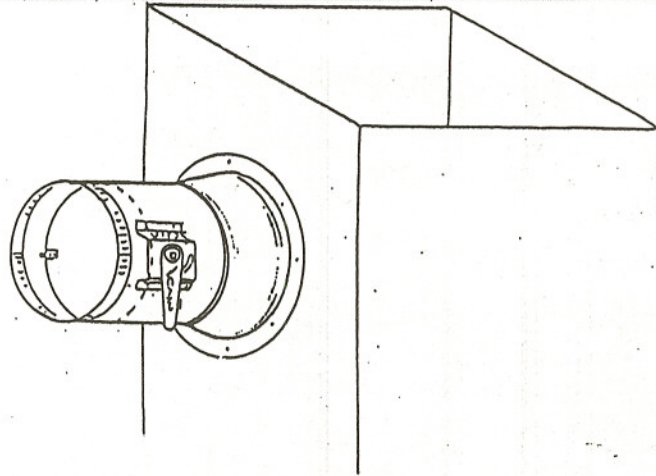

ELEVATED REGULATOR



DH CBS 14



DH CBS WN

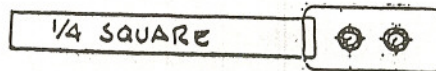

DH CBS 14L

FOR USE ON 4, 5, 6, 7, OR 8" DIA. DAMPERS
DO NOT USE ON LARGER DAMPERS

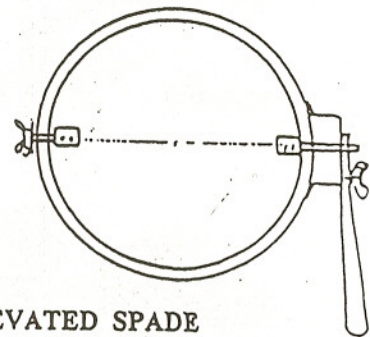

ELEVATED SPADE
ASSEMBLY

Cain
MANUFACTURING COMPANY, INC.
QUALITY HVAC PRODUCTS SINCE 1935

CAIN

Snap - Loc

Nylon Bearing Inserts

Q. HOW DO YOU FIT A SQUARE BEARING INTO A ROUND HOLE?

A. SIMPLE ! USE CAIN'S NEW EXCLUSIVE SELF LOCKING NYLON INSERTS.
JUST SNAP THE SELF LOCKING INSERT INTO THE PRE-DRILL HOLE AND **PRESTO !**

IN AN INSTANT YOU HAVE AN AIR - TIGHT BEARING !

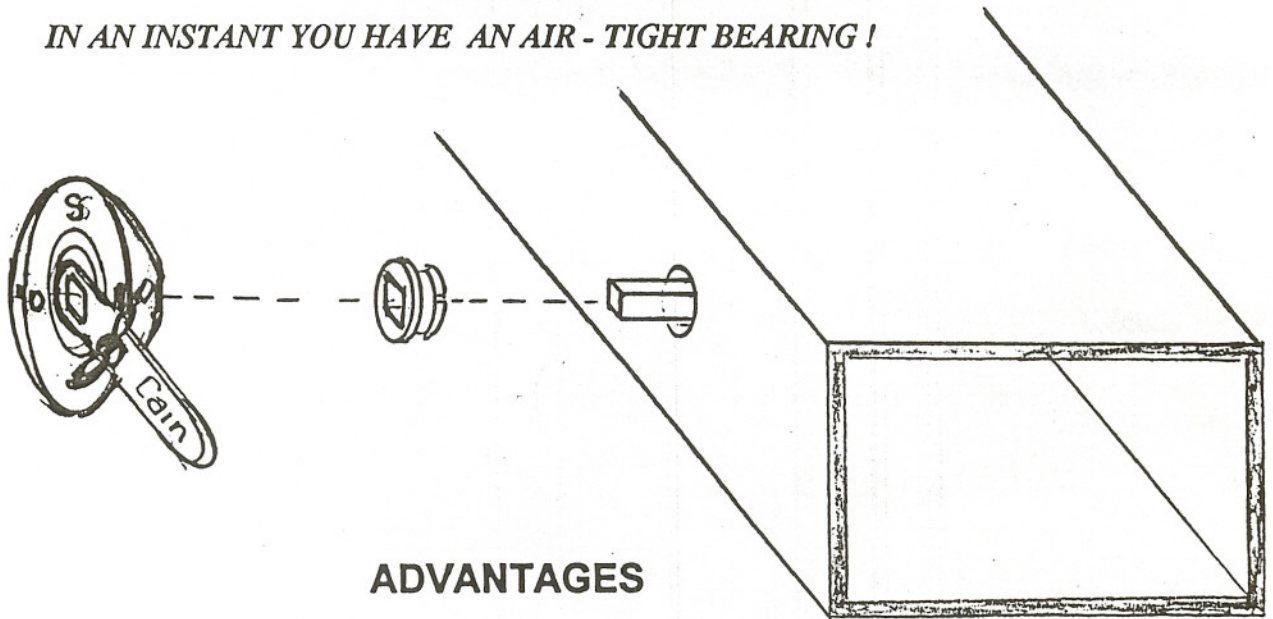

ADVANTAGES

1. SOLVES AN INDUSTRY OLD PROBLEM.
2. VIRTUALLY AIR TIGHT.
3. EASY TO INSTALL - THUMB PRESSURE SNAPS AND LOCKS INTO PLACE.
4. SAVES MONEY -- REDUCES AIR LOSS.
5. EASY TO ROTATE NYLON INSERT--AN EXCELLENT BEARING SURFACE.
6. LOW COST -- JUST PENNIES PER INSERT.
7. AVAILABLE FOR 1/4" & 3/8" SQUARE AND ROUND BEARINGS.

ANOTHER QUALITY PRODUCT FROM CAIN.

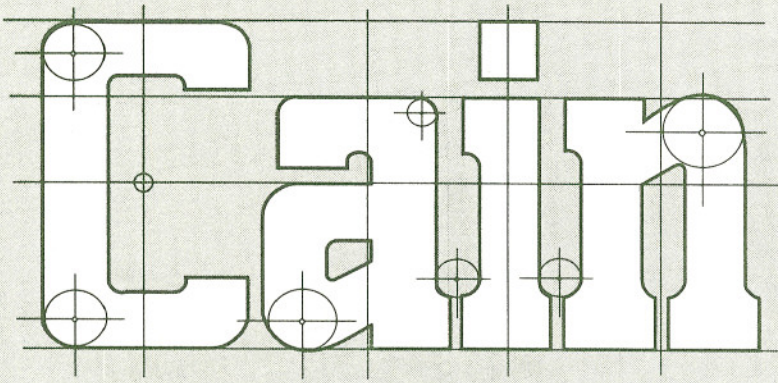

**DAMPER SLIDE PINS
ADAPTER SLIDE PINS
FOR
MULTI-BLADE
DAMPERS**

DAMPER SLIDE PIN & ADAPTER SLIDE PINS



DSP 1

DAMPER SLIDE PIN

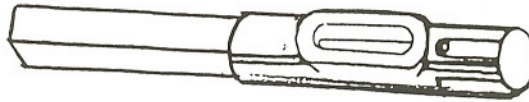

ASP 2



DSP 3

DSP 4

PRICED EACH

MODELS

- DH DSP 1 1/2" DIA. X 2 1/2" LG SLIDE PINS
- DH ASP 2 1/2" DIA. X 3/8" SQ. X 4 1/2" LONG
- DH DSP 3 1/4" X 20 CARRIAGE BOLT (100 BAG)
- DH DSP 4 1/4" X 20 HEX HEAD LOCK NUT (100 BAG)

